

Machine Protection Door

ASSA ABLOY RP300 / RP300 Wide / RP300 USD

ASSA ABLOY

ASSA ABLOY Entrance Systems

The global leader in
door opening solutions





HIGH SPEED

Rapid opening and closing ensures short cycle time.



HIGH RELIABILITY

High reliability and low service even after years of high numbers of cycles.

HIGH SAFETY

Safety contact edge or touchless safety edge. Safety limit switches according to PLe and SIL3.

Machine Protection Door **ASSA ABLOY RP300 / RP300 Wide / RP300 USD**

The demands in automated manufacturing processes are high and the smallest interruption or delay can break down the flow of production or endanger employees. Machine protection doors help manufacturers avoid both scenarios. The doors are integrated into the processes and open and close according to the production run. They enable the rapid change from complete isolation of the production step to free access to work piece and machine within seconds. It allows short cycle times and can be installed in machines, on production lines and railing systems within close proximity to the machine. Plus, they protect people in highly automated areas, making processes much safer.



Machine protection door benefits

- Rapid opening and closing ensures short cycle times up to 5 cycles per minute
- High reliability even after years of high numbers of cycles
- Safety limit switches according to EN ISO 13849-1 and EN 62061
- Doors conform to EN ISO 12100 and EN ISO 14119
- Versions conforming to various factory standards are possible
- Type tested machine protection door with fabric door blade

Advantages of the ASSA ABLOY RP300/RP300 Wide/RP300 USD

- Service friendly: Two-pieced aluminum side frames offer easy access for inspection and maintenance
- Pre-running photocell: in combination with control system Albany MCC a pre-running photocell is available as option. It provides more comfort and higher closing speed
- Integrated cable chain: The cables of the electrical safety contact edge and pre-running photocell are guided in cable chains inside the side frame
- Pluggable cables in the cable chain
- Drive unit: A chain drive is available as option in case of space limitations

Connection with the machine

The in- and outputs of the door control unit MCC (potential 24 V DC) can be connected directly, to the machine. The in- and outputs of the door control unit MCC and ACS 50 can be connected potentialfree with the machine. As standard the following signals are available:

- 2 potential-free safety contacts, when the door is closed (safety limit switch)
- 1 output or potential-free signal, when the door is open
- 1 output or potential-free signal when the door is closed
- 1 output or potential-free signal for faults

Machine Protection Door [ASSA ABLOY RP300 / RP300 Wide / RP300 USD](#)



Design

Side frames

The side frames are made of aluminum profiles. The front cover side frame can easily be removed and allows easy access for inspection and maintenance.

Door curtain

Depending on the application, various door curtains and colors are available (see details in the table). From partially transparent PVC curtains with colored reinforcement stripes with a high degree of transparency to highly rigid RollTex® and NomaTex®. All door curtains are silicon-free. Side-mounted wind tabs reduce inward bending of the door blade. RollTex® according to TRAV (technical rules for use of anti-fall guard vitrification).

Windows

For process monitoring when the door is closed, various window variants are available. On PVC curtains with colored reinforcement strips, there are large viewing areas. For all other variants of curtains, optional horizontal or vertical windows are integrated in the door curtain. Also anti-UV windows conform to EN 1598.

Drive unit

Gear motor with safety gear box including catching device, mounted on the right or left side.

Control system

Depending on the application there are 2 control systems which offer a broad spectrum of speeds, power supplies and options for connecting control and safety devices.

Standard: ACS 50 Option: frequency converter control MCC

Upon request the door can also be delivered without a control system (not Upside Down). Extension box: Space saving extension box for MCC allows mounting of interface card or safety monitoring module for safety limit switches.

Safety limit switch integrated in side frame

For the indication “door safely closed”, safety limit switches are integrated in the side frame. Optional evaluation by safety systems of the machine (version without safety monitoring module). Due to the use of safety limit switches, machine protection doors cannot be equipped with a knock-out mechanism.

Motor cover and top roll cover

Motor cover is made of powder coated steel plate (RAL 9006). Top roll cover is made of aluminium.



Model ASSA ABLOY RP300 USD

The new Albany RP300 USD (Upside Down) machine protection door is designed so that you can integrate it into your production area where bigger components and machinery must be arranged vertically.

Integrated cable chain

Integrated cable chain guides cables for pre-running photocell or electrical safety contact edge inside the side frame.

Manual activation

During a power failure the door can be opened manually using a hand crank.

Safety features

The bottom profile is monitored by an electrical safety contact edge. As an option, the door can be equipped with a pre-running photocell in combination with the control system MCC (Standard on Upside Down). A door line photocell also prevents the door from closing when objects are interfering.

CE guidelines

This door is designed according to the regulations of the Workplace Directive of the UVV as well as the harmonized CE Guidelines including the EN 13241-1 and 2006/42/EG.

Indication of risk

The security of the door is designed for normal use for vehicles in industrial environments corresponding to the harmonized CE-Guidelines. In addition, special environmental conditions may impact the type of door necessary. For clarification and details, please contact your local sales engineer.

General drawing ASSA ABLOY RP300

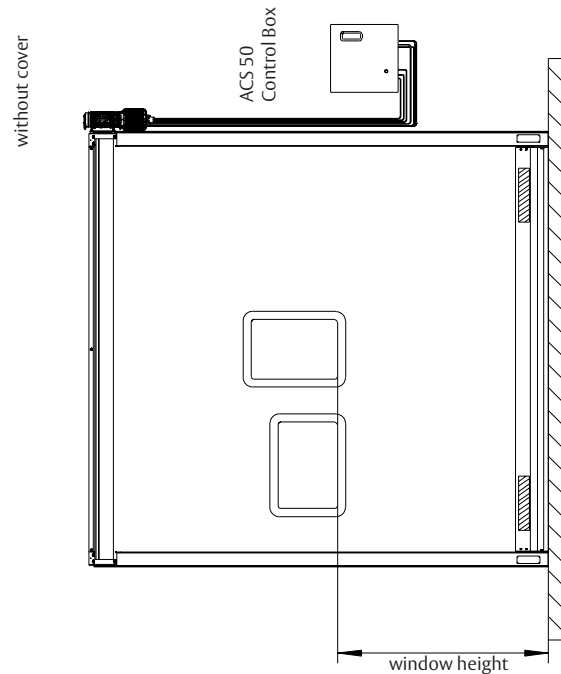
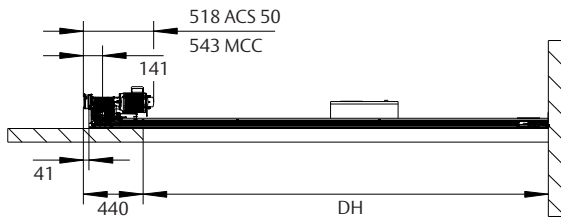
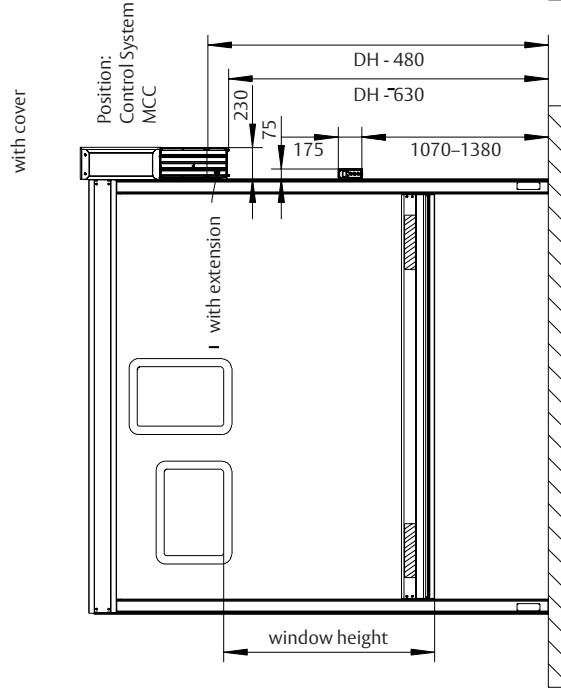
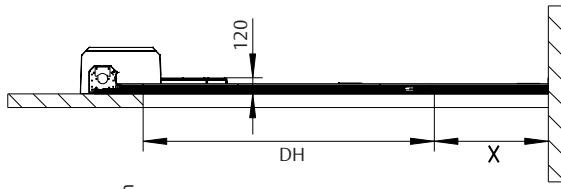

Option X-Level
Door does not close to floor, but down to X-Level

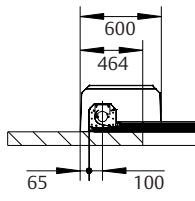
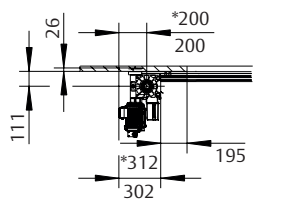
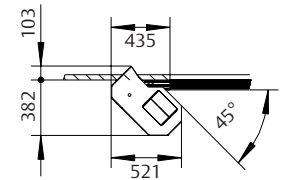
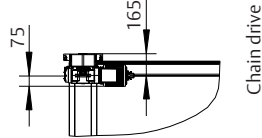
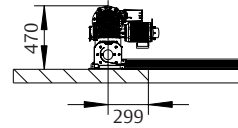
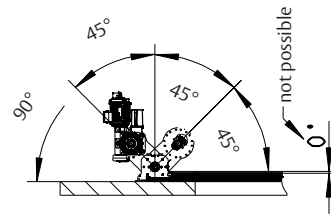

drive unit- and chain drive position not drawn at request

Tolerance ± 3 mm (for all dimensions)

Dimensions in [] = clearance for installation

9300R0001/c

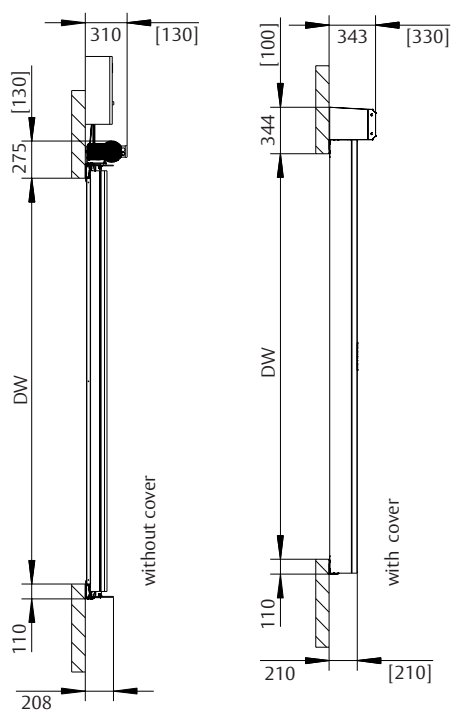
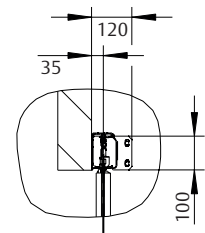
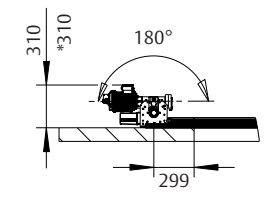

General drawing ASSA ABLOY RP300 Wide

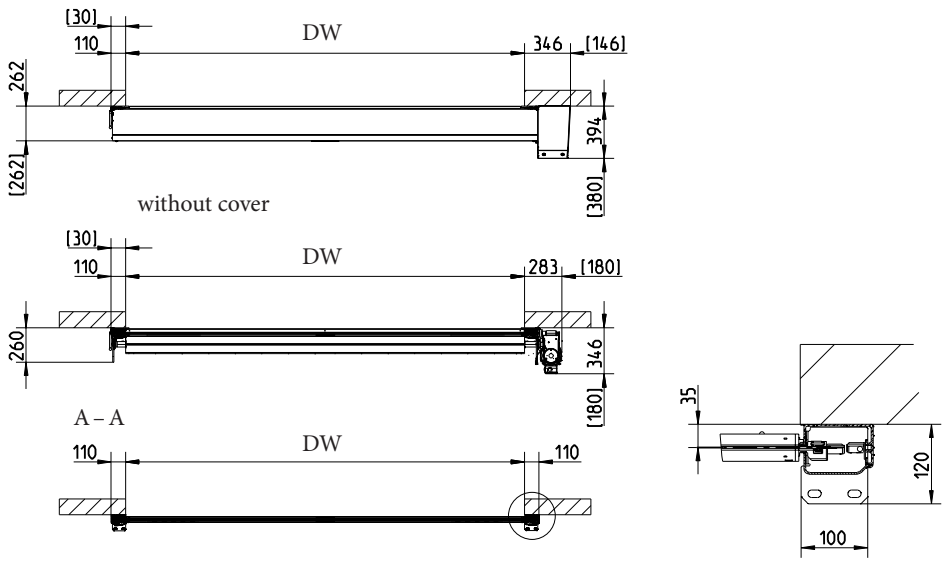
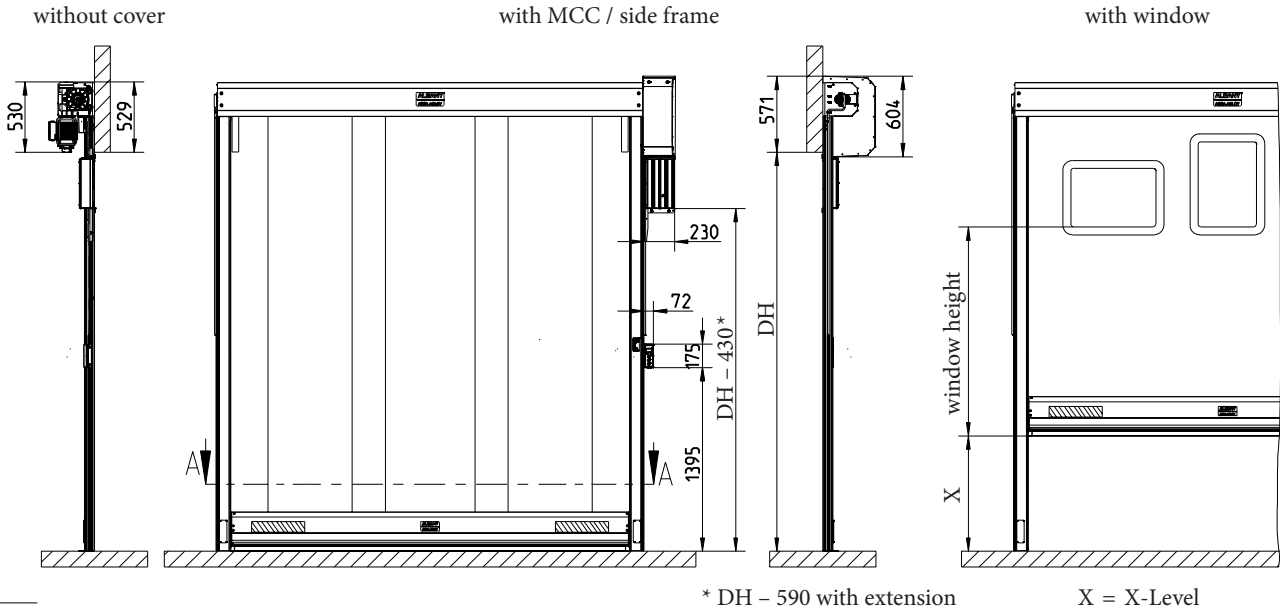

Available sizes		
	DW (B)	DH (H)
min. (mm)	750	750
max. (mm)	6000	5000
DW > 4000 or DH > 3500		

[] = Space needed for installation

General drawing ASSA ABLOY RP300 USD

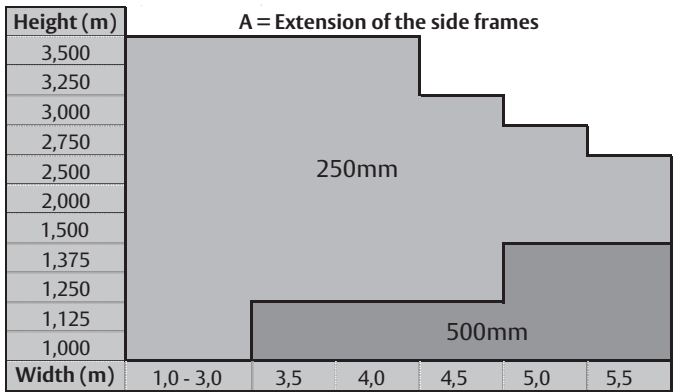
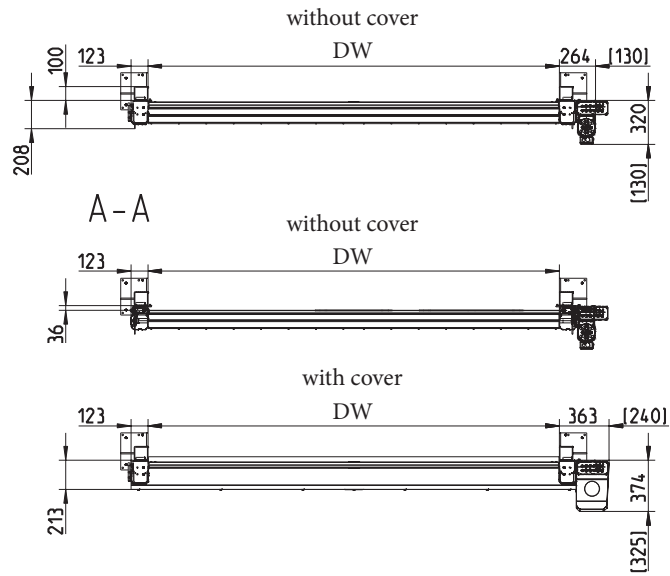
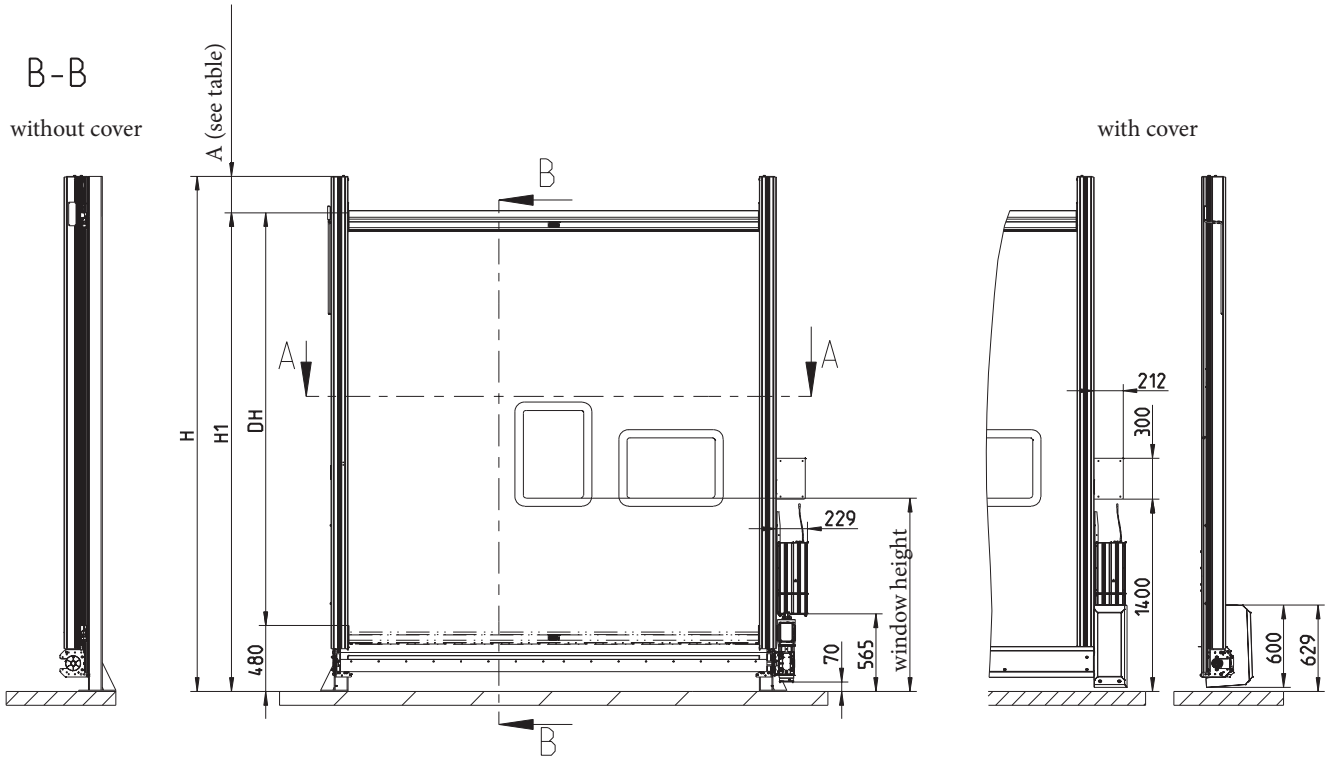

Available sizes		
	DW (B)	DH (H)
min. (mm)	1000	1000
max. (mm)	5500	3500

[] = Space needed for installation



Technical information ASSA ABLOY RP300 / RP300 Wide / RP300 USD

	ASSA ABLOY RP300	ASSA ABLOY RP300 Wide	ASSA ABLOY RP300 USD
Application	Interior door / Machine Protection Door	Interior door / Machine Protection Door	Interior door / Machine Protection Door
Door dimensions (mm) (DW min./max.) (DH min./max.)	750 / 4000 mm 750 / 3500 mm	750 / 6000 mm 750 / 5000 mm	1000 / 5500 mm 1000 / 3500 mm
max. area	14 m ²	30 m ²	14 m ²
Opening direction	vertical	vertical	vertical
Wind resistance (EN 12424)	class 1 (max. 11 m ²)	class 1 up to DW ≤ 5600 mm	class 1
Noise emission	< 70 dB A	< 70 dB A	< 70 dB A
Temperature range max. (Extended on request) ³⁾	+10°C – +45°C (0 up to +60°C) ³⁾	+10°C – +45°C (0 up to +60°C) ³⁾	+10°C – +45°C (0 up to +60°C) ³⁾
Surface material			
Side frame	✓ Anodized aluminum	✓ Anodized aluminum	✓ Anodized aluminum
Top roll cover	• Anodized aluminum	• Anodized aluminum	✓ Anodized aluminum
Bottom profile	✓ Anodized aluminum	✓ Anodized aluminum	✓ Anodized aluminum
Motor cover	• Powder coated steel, RAL 9006	• Powder coated steel, RAL 9006	• Powder coated steel, RAL 9006
Extension side frame	–	–	250 – 500 mm (depending on doortype)
Safety features			
Electrical safety contact edge	✓	✓	–
Door line photocell	✓	✓	–
Pre-running photocell (only in combination with MCC, Door line photocell as option)	•	•	✓
Drop down protection in drive unit	✓	✓	–
Pre-running photocell ²⁾	–	–	✓
Emergency egress	Crank handle	Crank handle	Crank handle
Counterbalance	–	–	Counterbalance
Equipment			
LED traffic light	•	•	•
Traffic light / Flashing alarm light	•	•	•
Suitable machine protection	✓	✓	✓
Magnetic switch in side frame	✓ 1 piece / • 2 piece	✓ 1 piece / • 2 piece	✓ 1 piece / • 2 piece
Window in sideframe, view on magnetic switch	•	•	•
Drive unit			
Motor power	0,75 kW	0,75 kW	0,75 kW
Chain drive	•	•	–
Gear heating	•	•	•
Control system	✓ ACS 50 / • MCC	✓ ACS 50 / • MCC	✓ MCC
Control system			
MCC Open/Close max. (m/s) ²⁾	• 2,4 / 1,3 2,4 / 1,75 (pre-running photocell)	• 1,7 / 1,0 1,7 / 1,1 (pre-running photocell)	✓ 2,2 / 1,5
ACS 50 Open/Close max. (m/s) ²⁾	✓ 1,0 / 1,0	✓ 0,8 / 0,8	–
Cycles per minute max. * exact number of cycles depending on application	ACS 50 = 1 MCC = 3 up to 5*	ACS 50 = 1 MCC = 1 up to 1,5*	MCC = 5*
Separate display / control	only at MCC	only at MCC	only at MCC
Fuse protection by site	10 A (C-characteristic) (at 220/230V 16 A)	10 A (C-characteristic) (at 220/230V 16 A)	10 A (C-characteristic) (at 220/230V 16 A)
Control voltage	24 V DC	24 V DC	24 V DC
Protection	IP 55	IP 55	IP 55
Potential-free contacts	•	•	•
UL-Version 	• ACS50 • MCC	• ACS50 • MCC	• MCC
Network connection			
ACS 50	Standard: 3L(N)PE/220/230/380/400/415V; 50Hz with transformer: 3L(N)PE/440/480/500V; 50Hz UL-Version: 3L(N)PE/208/220/230/460/480V; 60Hz	–	–
MCC	Standard: 3L(N)PE/380/400/415/440/460/480V; 50/60Hz with transformer: 3L(N)PE/220/230/500V; 50Hz UL-Version: 3L(N)PE/208/220/230/460/480V; 60Hz	–	–



Safety limit switch

Optional: For the indication “door safely closed”, safety limit switches are integrated in the side frame.



Floor mounting brackets

The door can be mounted freestanding on floor with optional mounting brackets. Levelling screws allow adjustment by uneven floor.

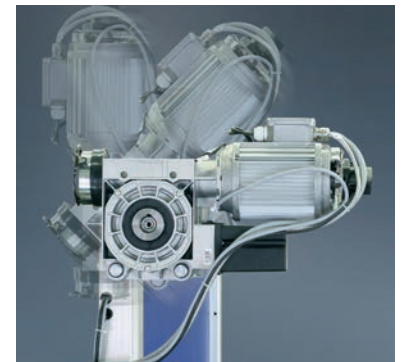

Motor position

Motor can be mounted right- or lefthand side. Motor position can be chosen in step of 45°. A chain drive is available as option in case of space limitations.

- Option
- ✓ Standard
- *) Specific number of cycles on request

- 1) For doors of height < 2300 mm the use of top roll cover is required according to standard EN 13241-1.
- 2) Deviations possible depending on other properties
- 3) Depending on cycles/minute, door size and installation location



ASSA ABLOY Entrance Systems is a leading supplier of entrance automation solutions for efficient flow of goods and people. With our globally recognized product brands ASSA ABLOY, Besam, Albany and Megadoor, we offer products and services dedicated to satisfying end-user needs for safe, secure, convenient and sustainable operations. ASSA ABLOY Entrance Systems is a division within ASSA ABLOY.

ASSA ABLOY

assaabloyentrance.us • assaabloyentrance.ca

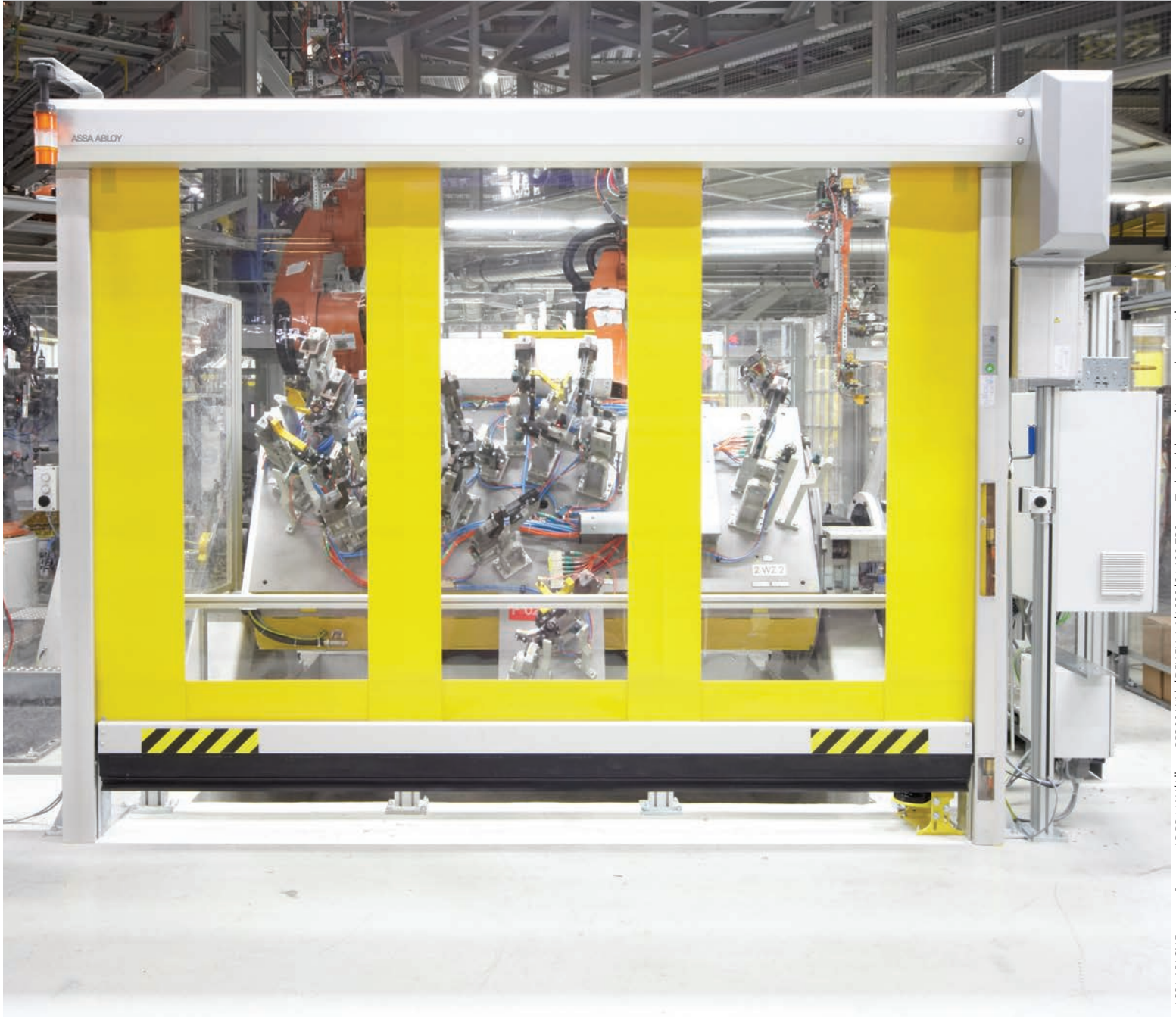

© ASSA ABLOY Entrance Systems AB BR.MAN/Albany RP300 Wide/DEU.EN-1/1608/64 100 728 Technical data subject to change without notice



ASSA ABLOY Entrance Systems

Tel: 1-800-252-2691
info.na.aaes@assaabloy.com
assaabloyentrance.us • assaabloyentrance.ca

Follow us:



Please enter ASSA ABLOY Entrance in the channel's search field.